

# Mobil lubricants and greases for wind turbines.

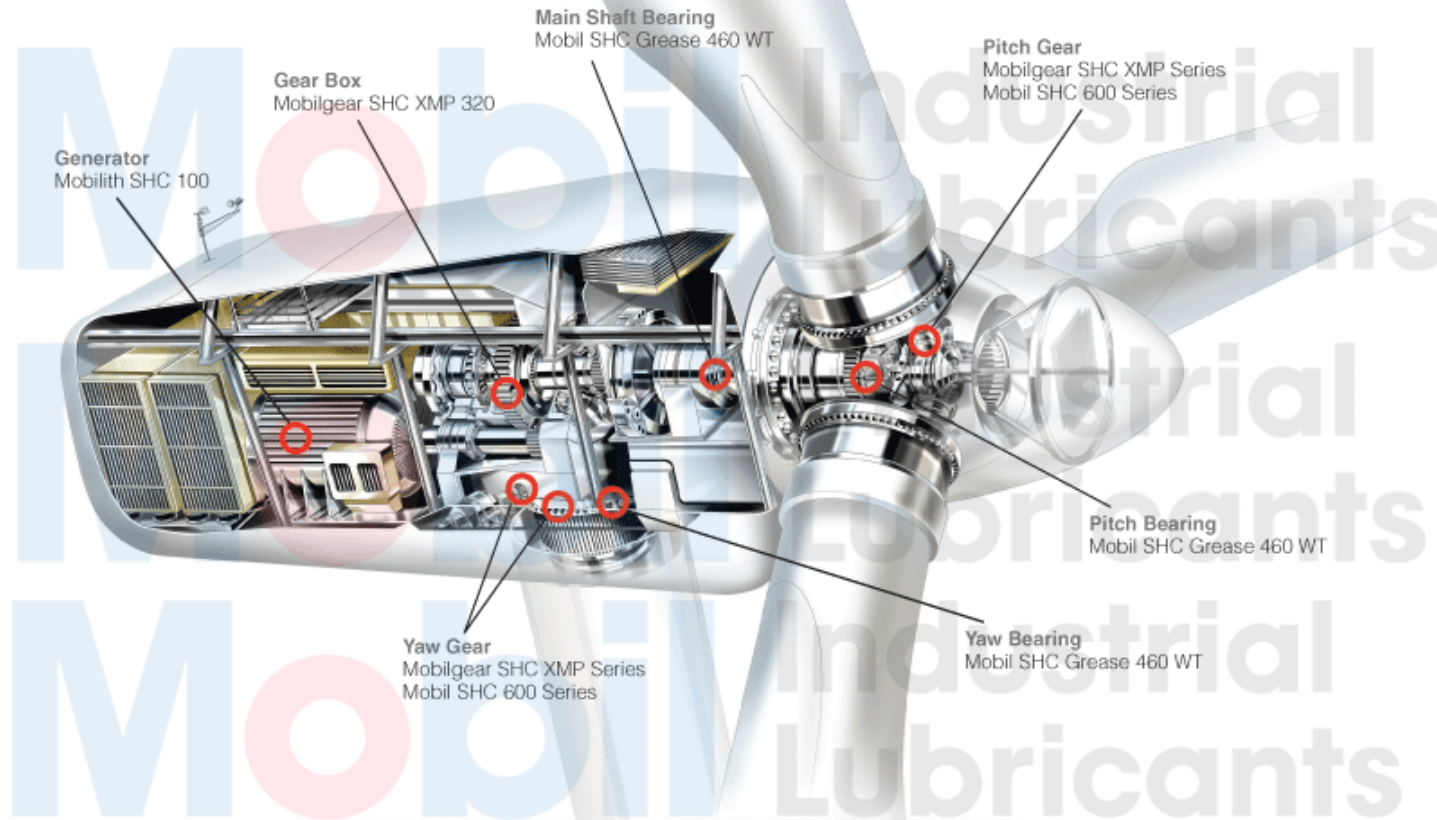

**Generator**  
Mobilith SHC 100

**Gear Box**  
Mobilgear SHC XMP 320

**Main Shaft Bearing**  
Mobil SHC Grease 460 WT

**Pitch Gear**  
Mobilgear SHC XMP Series  
Mobil SHC 600 Series

**Pitch Bearing**  
Mobil SHC Grease 460 WT

**Yaw Gear**  
Mobilgear SHC XMP Series  
Mobil SHC 600 Series

**Yaw Bearing**  
Mobil SHC Grease 460 WT

**Hydraulic System**  
Mobil SHC 524

**Open Gear**  
Mobilgear OGL 007\*  
Mobiltac 375 NC\*

\*non-synthetic

**Mobilgear SHC XMP Series**  
synthetic gear oil for the main gearbox

**Features:** Superb all-around protection against gear and bearing wear (such as micropitting and scuffing wear); excellent foam and air release; outstanding stability in the presence of water contamination; corrosion protection.

**Advantages and Benefits:** Improved equipment productivity due to reduced unscheduled downtime and maintenance; longer gear and bearing life under high-stress operating conditions; extended oil life.

**Mobil SHC 524**  
synthetic hydraulic oil

**Features:** Maximum antiwear protection; highly shear stable; wide temperature range; resistant to deposit formation.

**Advantages and Benefits:** Ideally suited for high-pressure and tight-clearance hydraulic systems; improved cleanliness and longer life for components (pumps and valves); extended oil and filter life.

**Mobilith SHC Greases**  
synthetic greases for lubrication of main, pitch, and yaw bearings (Mobil SHC Grease 460 WT) and generator bearings (Mobilith SHC 100)

**Features:** Outstanding high- and low-temperature performance; excellent extreme pressure (460) and antiwear (100) properties; low starting and running torque; very good structural stability; resistance to water contamination.

**Advantages and Benefits:** Improved flexibility in geographic placement of wind turbines; excellent wear protection of components; easy start-up at low temperature; extended regreasing interval—reduced service cost.

**Mobil SHC 600 Series**  
synthetic gear and bearing oils for ancillary wind turbine gearboxes

**Features:** Excellent high- and low-temperature capability; superior wear protection; highly resistant to oxidation and sludging; low traction coefficient.

**Advantages and Benefits:** Extends ambient temperature for equipment; improved operational reliability; extended oil life; improved energy efficiency.

**Mobiltac 375 NC\***  
non-synthetic lubricant for open gears

**Features:** Nonleaded, diluent-type open gear lubricant; high viscosity base oil for heavily loaded open gears; excellent protection of gear teeth and other machine elements under boundary lubrication conditions.

**Advantages and Benefits:** Excellent gear wear protection; low component replacement and maintenance costs.

**Mobilgear OGL 007\***  
non-synthetic, non-diluent lubricant for open gears

**Features:** Advanced technology, semi-fluid lubricant; extreme pressure additive and graphite for heavy loads; lead- and chlorine-free; adhesive in nature.

**Advantages and Benefits:** Excellent gear wear protection; low component replacement and maintenance costs; reduced environmental impact.

Format: GIF

Dimensions: 1112w x 820h

Size: 199.7K

Settings: Selective, 256 Colors, 100% Diffusion Dither, Transparency on, No Transparency Dither, Non-Interlaced, 0% Web Snap

```
<html>
<head>
<title></title>
<meta http-equiv="Content-Type" content="text/html; charset=iso-8859-1">
</head>
<body bgcolor="#FFFFFF" leftmargin="0" topmargin="0" marginwidth="0" marginheight="0">
<!-- ImageReady Slices () -->
<a href="http://www.mobilindustrial.com/Lubes/IND/industry/energy/wind_f.html">
    </a>
<!-- End ImageReady Slices -->
</body>
</html>
```